

OPERATING INSTRUCTIONS FOR YOUR RENTAL TIMES SQUARE LIGHTING FOLLOWSPOT

Your rental Times Square Lighting Followspot has been built and carefully tested to provide many years of trouble free and reliable service. Following these simple rules will help ensure the life of your fixture.

POWER CORD OPERATES INTERIOR FANS. LEAVE UNIT ON FOR ABOUT 2 MINUTES AFTER USE TO ALLOW THE UNIT TO COOL PROPERLY. UNPLUG UNIT WHEN NOT IN USE.

Place the yoke on top of the stand and screw the yoke tightly on until it stops. Then unscrew the yoke 1 ½ turns to allow the unit to pivot freely.

Using two persons, carefully lift the followspot body and line up the bolts from the yoke support plate with the slots in the yoke. Carefully lower the unit until the bolts contact the bottom of the yoke support plate. Tighten the yoke knobs to the desired tension allowing for free, but not loose movement of the unit.



Model #	Accessories/Spare Parts
FEL	1000W 110V Lamp
4.5x18.5	Rear Lens
6x20	Front Lens
QF1000 IRIS	Iris Assembly
QF1000 SHUTTER	Shutter Assembly
QF1000-8000	Socket Assembly
CS1000	Individual Caster
A47B15A15T3 FAN	Fan w/ Wire Guard
T-14877	Transformer
QF1000-6002	Iris Handle to Brass Rod
QF1000-6003	Shutter Handle to Brass Rod
90131A 553	Fiber Washer

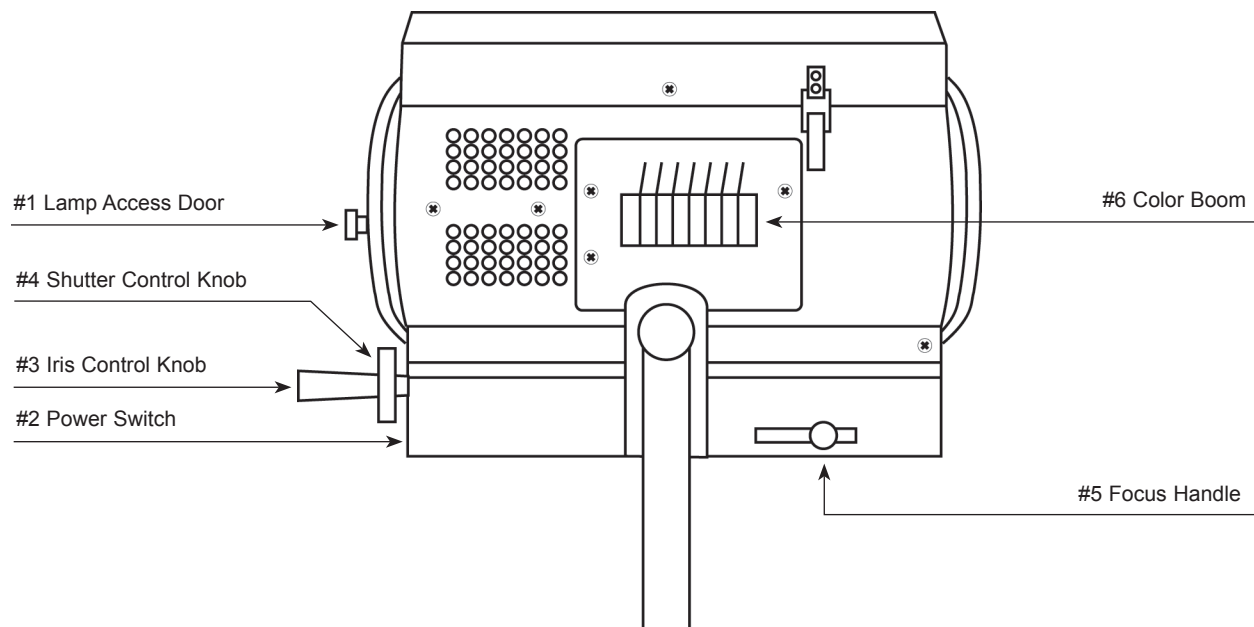

POWER CORD OPERATES INTERIOR FANS. LEAVE UNIT ON FOR ABOUT 2 MINUTES AFTER USE TO ALLOW THE UNIT TO COOL PROPERLY. UNPLUG UNIT WHEN NOT IN USE.

: PARTS/OPERATION

1. The power switch (#2) turns the unit on & off.
2. The narrow, black knob on the back of the unit (#3) controls the iris. The iris is used to control the circular spot size of the light. If the iris is open to its maximum, the light will spread to maximum. If the iris is closed, the light will concentrate to a small spot. If the iris is closed for more than 60 seconds, the unit must be turned off to prevent the lamp from burning the interior components.
3. The flat, black knob on the back of the unit (#4) controls the shutter. The shutter is used to control the framing of the top and bottom edges of the beam.
4. The long, black, narrow handle on the side of the unit (#5) is the focus handle. To operate the focus handle, turn the handle counterclockwise to loosen then slide the handle back and forth to achieve a hard or soft edge spot. After focusing, tighten the handle down.
5. The color boom (#6) is operated by depressing one or more of the colored knobs; this will bring the color media into line with the path of the light.
6. The dowser (black knob) will simulate a fade, when slowly lowered into position. As with the iris, it is best to turn the unit off if the dowser is in the down position for more than 60 seconds.

Remember, practice and experience are the best teachers. Practice with the unit before using it for a production.

If you have any additional questions or require further information please don't hesitate to contact our office 337-478-3116. We are here to help.