

# OPERATOR'S MANUAL

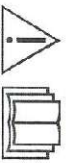
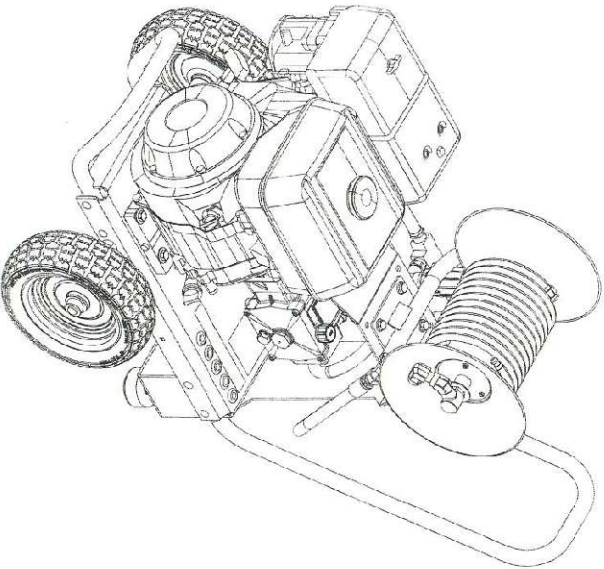

9-808-473.0-A (02/25)

## HOW TO USE THIS MANUAL

Thank you for purchasing this Jetter. This manual covers the operation and maintenance of model HD 3.3/25 J LETTER. All information in this manual is based on the latest product information available at the time of printing. We reserve the right to make changes at any time without incurring any obligation.

### Owner/User Responsibility:

The owner and/or user must have an understanding of the manufacturer's operating instructions and warnings before using this Jetter. Warning information should be emphasized and understood. If the operator is not fluent in English, the manufacturer's instructions and warnings shall be read to and discussed with the operator in the operator's native language by the purchaser/owner making sure that the operator comprehends its contents.

Owner and/or user must study and maintain for future reference the manufacturer's instructions.

### SAVE THESE INSTRUCTIONS

**This manual should be considered a permanent part of the machine and should remain with it if the machine is resold.**

**When ordering parts, please specify model and serial number. Use only identical replacement parts.**

**This machine is to be used only by trained operators.**

## MACHINE SAFETY

**WARNING:** To reduce the risk of injury, read operating instructions carefully before using.



1. Read the owner's manual thoroughly. Failure to follow instructions could cause malfunction of the machine and result in death, serious bodily injury and/or property damage.

2. All installations must comply with local codes. Contact your electrician, plumber, utility company or the selling distributor for specific details.

**CAUTION:** Risk of asphyxiation. Use this product only in a well ventilated area.



3. Avoid installing machines in small areas or near exhaust fans. Exhaust contains poisonous carbon monoxide gas; exposure may cause loss of consciousness and may lead to death. It also contains chemicals known, in certain quantities to cause cancer, birth defects or other reproductive harm.



**WARNING:** Risk of fire. Do not add fuel when the product is operating.



**WARNING:** Risk of explosion — do not spray flammable liquids.

4. Do not place machine near flammable objects as the engine is hot.
  5. Allow engine to cool for 2 minutes before refueling. If any fuel is spilled, make sure the area is dry before testing the spark plug or starting the engine. (Fire and/or explosion may occur if this is not done.)
- Gasoline engines on mobile or portable equipment shall be refueled:
- a. outdoors;
  - b. with the engine on the equipment; stopped;
  - c. with no source of ignition within 10 feet of the dispensing point; and
  - d. with an allowance made for expansion of the fuel should the equipment be exposed to a higher ambient temperature.

In an overfilling situation, additional precautions are necessary to ensure that the situation is handled in a safe manner.



**CAUTION:** High pressure stream of water that this equipment can produce can pierce skin and its underlying tissues, leading to serious injury and possible amputation.



**WARNING:** High pressure spray can cause particles to become airborne and fly at high speeds.



5. Eye safety devices (rubber gloves, ear plugs and foot protectors) must be worn when using this equipment.



6. High pressure developed by these machines will cause personal injury or equipment damage. Use caution when operating. Do not direct discharge stream at people or severe injury or death will result.

7. Never make adjustments on machine while it is in operation.

## SAFETY

8. Do not operate valve in the off position for extended periods of time as this may cause damage to the pump.
  9. The best insurance against an accident is precaution and knowledge of the machine.
  10. Manufacturer will not be liable for any changes made to our standard machines, or any components not purchased from us.
  11. Read engine safety instructions provided.
- WARNING: Keep water spray away from electric wiring or fatal electric shock may result.**
12. Never run pump dry.
  13. Do not allow children to operate the letter at any time.
  14. Inlet water supply must be cold and clean fresh water.



## ASSEMBLY

Upon arrival, inspect the shipping crate for damages. Uncrate and examine all parts. Note any damage to machine or components for claims against freight carrier.

The tires on the jets may be partially deflated for packing and shipment. Reinflate tires to the pressure specified on the side of the tire before using the machine.

Jetter have an antifreeze in the pump to protect it from freezing conditions during shipment and storage. If machine will be stored and operated in a cold climate, follow Freeze Protection instructions on page 9.

## PRE-OPERATION CHECK

1. Pump oil (SAE 30W non-detergent oil, General)
2. Cold clean fresh water supply (6 gpm • 3/4") (1.5 @ 7.5 min) • (20 psi)
3. Hose, nozzle
4. Fuel (unleaded 85 or higher octane)
5. Engine oil (SAE 10W40)

## SET-UP PROCEDURES

These machines are meant to be used at or near the working area and under operator supervision. If machine must be located out of sight of the operator, special controls may be required for proper machine operation and operator safety.

Locate the equipment on a solid level area with slopes for drainage. Avoid areas where water can be sprayed at machine.

Before using the jet, make sure there are no impediments in the incoming water supply. Turn the water source on for at least 15 seconds, to remove any possible debris in the water before connecting hose to water inlet swivel.

Operation Manual Letter 3-308-473.0

The inlet screen located inside the filter should be cleaned before each use. To clean the inlet screen, unscrew cap beneath the filter, remove the screen, and rinse thoroughly with water. Then replace screen. Connect one end of a garden hose (not included) to the water faucet — water supply not to exceed 100 psi (6.9 bar) and the other end to the water inlet of the jet machine. (See component identification drawings on next pages.) Use heavy duty 3/4" hose of no more than 50 ft. (15m) in length. If run without an adequate water supply, the pump will cavitate. Cavitation causes the pump to vibrate, causing damage to the pump.

**NOTE: Lack of water supply can lead to seal damage, causing a loss of pressure and will void the warranty to the pump.** Maximum temperature from the water source should not exceed 140°F (60°C). Using water hotter than 140°F (60°C) can cause damage to the pump and void the warranty. If jets is being used to clear ice blockages, see instructions on page 10. Remove oil plug on top of pump and replace with dipstick supplier. Fill engine with oil. Refer to engine manual for quantity.

**Hose Selection Guide**

Select the proper hose diameter for the line to be cleaned. When using new hose, run water through it to clean it out before attaching the nozzle.

Hose Size (ID)*	Pipe Size	Typical Applications
3/8" or 5/8" (9.825mm or 7.350mm)	4" to 8" (102mm to 203mm)	Floor drains, septic lines long runs
1/4" (6.35mm)	2" to 4" (51mm to 203mm)	Kitchen sinks, laundry drains, clean outs
1/8" (3.175mm)	1-1/2" to 2" (38mm to 51mm)	Small lines, bathroom sinks, light fixtures

When selecting hose size, consider that pressure is lost as the water travels down the length of the hose. As the length increases, the pressure decreases. In addition, the smaller the diameter of the hose the greater the loss of pressure per foot will be. As an example, at 2 GPM (1.3L/sec) a 1/4" (6.35mm) hose will lose 180 lbs. (12.4 bar) of pressure over 100 ft. (30.5m) of hose, yet a 3/8" (9.825mm) hose will only lose 25 lbs. (1.7 bar) of pressure over the same length and at the same flow rate. At 4 GPM, a 3/8" hose will lose 90 lbs. (6.2 bar) of pressure over a 100 ft. (30.5m) length. The gauge reflects pressure from the pump only, not pressure at the end of the hose. It is important to select the largest possible hose size in order to have as much pressure as possible at the end of the hose.

5

## COMPONENT IDENTIFICATION

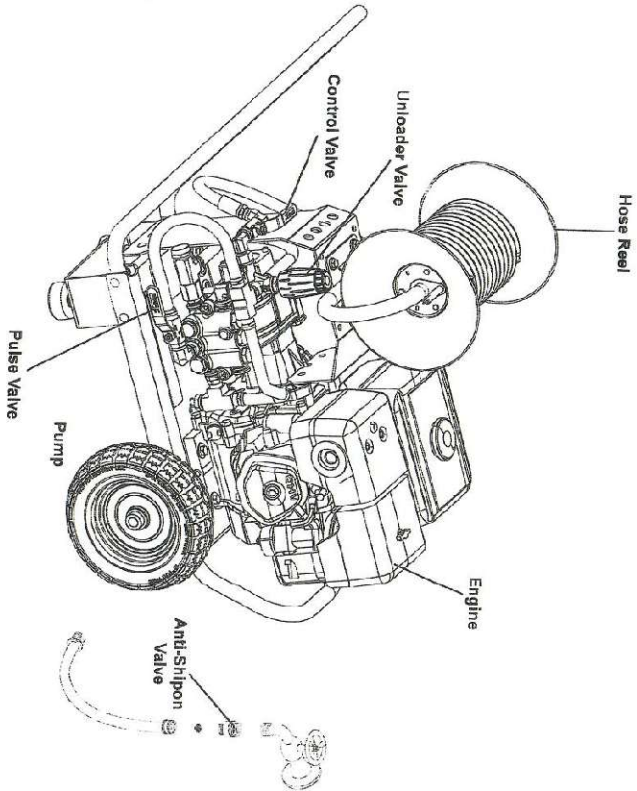

6

Operation Manual Letter 3-308-473.0

## SAFETY

Hoses of the same diameter may be coupled together using a screw coupling, but it is not recommended for use in lines smaller than 3" (203mm) in diameter. The long length of the hose connectors and coupling together can get caught in bends in the line.

PART NUMBER	ADAPTER SIZE (FPT)
8.705-564.0	1/4" x 1/4"
8.705-566.0	3/8" x 3/8"
8.705-569.0	1/2" x 1/2"
8.705-571.0	3/4" x 3/4"

Coupling two different size hoses can be done through the spray wand trigger or foot pedal.

It is not advisable to have two different hose sizes coupled in a drain line. There is a tremendous loss of pressure when combined, aside from the difficulty of getting around bends.

The 3/8" (9.925 mm) and 1/4" (6.35 mm) hoses may be attached to the fitting in the core of the hose reel using the swivel at one end of the hose. The 3/8" hose may also be attached directly to the accessory outlet by using a twist connect. The 1/4" and 1/8" (3.175mm) hoses may be connected directly to the accessory outlet if an adapter fitting is used between the hose and quick connect. Adapter's may be ordered separately. Often the 1/8" hose is used in conjunction with the spray wand trigger to give the operator finger tip control.

Remove the spray wand from the trigger and attach the 1/8" hose using the appropriate adapter. A SFP valve is available that can be used as a safety shut-off valve for all hose sizes. See foot pedal section for installation and operating instructions.

### Nozzles

A number of types of nozzles are available for drain cleaning. Each has a different spray pattern. Some nozzles may have a hole in the front to cut through the stoppage. All will have holes in the back to drive the hose down the line and clean the walls of the pipe. A combination of nozzles may be required to clear a line.

Always turn off the machine and shut off valve before changing nozzles. Make sure the nozzle you are using matches the pump size. A 3300 psi (207 bar) pump requires a different nozzle orifice than a 1500 psi (104 bar) pump. Mismatching nozzles with pump size will either cause too little pressure which may not clear the drain, or too much pressure which may damage the machine.

Check nozzles before and after each use for clogged holes which can cause pressure to increase to dangerously high levels and damage the pump. A clogged hole can be cleared by simply using a nozzle cleaning tool.

Use the nozzle selection guide to determine what nozzle you will need for various applications.

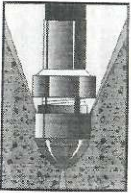

Powerful penetrating nozzle cuts through grease and ice.

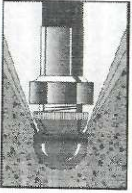

Wide spray flushing nozzle cleans inside of pipe thoroughly.



Rotary nozzle scours walls of pipe crystal clear.

### Nozzle Selection Guide

	1/8"	1/4"	3/8"
No Forward Jet	8.710-0476.0		
1 FWD / 3 BACK	8.761-590.0	8.710-8782.0	8.751-4511.0
Rotating Nozzle	8.710-5980.0	8.710-8993.0	

### Rotary Nozzles

Rotary nozzles are useful as a finishing tool. After the line has been cleared, you may switch to the rotary nozzle to more thoroughly clean the walls of the pipe. Use these nozzles only in a predominantly straight run since they are longer than regular nozzles and may get caught in tight bends. Please note that the rotating nozzles will operate at a lower pressure than the standard nozzle.

Rotary nozzles can be adapted using the nozzle adapters and bushings below.

### Nozzle Adapters And Bushings

Part Number	FPT x MPT
9.803-054.0	1/4" x 1/8"
8.705-185.0	3/8" x 1/8"
9.804-007.0	3/8" x 1/4"

7

## SAFETY

Part Number	FPT x MPT
9.803-564.0	1/8" x 1/4"
8.705-1293.0	1/4" x 3/8"

### Pre-Operation Checklist

- Be sure you understand all safety precautions and have been trained to use the machine.
- Wear goggles or a face shield to protect your eyes from spray and from any product of the spray.
- Wear gloves, rubber boots and other protective clothing as required.
- Be sure you understand all safety precautions for the detergent use.
- Check the labels of any substance you will spray, if the label recommends any antidote or treatment, be ready to use it.
- Check that all lines and hoses are clear.
- Check that the machine is connected to an adequate water supply and that the water supply is on.
- Check that traffic has not made the hose weak, worn or damaged. Check the hose for pinching or kinking.
- Repair any damaged hose.
- Tighten all fluid connections securely.
- Check gasoline and oil level of engine. See enclosed manufacturer's manual for engine and oil types.

## OPERATING INSTRUCTIONS

Read engine warning and operating instructions. Failure to follow instructions can cause serious injury and damage to equipment. Be familiar with all pre-operation checklists. Check all hoses for wear and damage. Tighten all connections securely. Check oil level of pump. Check engine fuel and oil levels. To begin, turn the water faucet on fully and purge air from system. Insert end of the jet hose 2 to 3 feet into the drain line. Then turn the valve on.

**WARNING: Never point the end of the jet hose at a person while operating.**

### Gas Engine Start-Up

1. Make sure that the ball valve is turned on and water is flowing.
2. Turn fuel valve to the open position.
3. Move choke lever to the closed position. NOTE: Do not use choke if engine is warm or ambient air temperature is high.
4. Move throttle lever to the midpoint position.

8

5. Turn the engine switch to the ON position.
6. Pull the starter grip lightly until resistance is felt, then pull briskly.
7. As the engine warms up, gradually move the choke lever to the open position.
8. Position the throttle to the desired engine speed.

### Pulse Technology

Pulsation makes the hose vibrate, helping the jet go longer distances and around tight bends easier. The pulse control valve is located on the front of the pump. Simply turn the valve on to engage the pulse. Pulse technology causes a pressure drop when it's engaged.

The pulse is most effective in a 1/8" hose. You'll note less vibration with a 1/4" hose and almost none with a 3/8" hose. However the pulse is still effective, causing the water to burst from the nozzle hundreds of times per second. If you are still having difficulty getting a hose around a tight bend, switch to a smaller diameter hose. Turn the pulsation valve off before turning machine off.

### Shut Down Instructions

After drain clearing or spray washing is completed, run clear water through the system. Always leave ball valve in open position when turning off engine. Reduce engine to idle, turn off engine and then be sure to turn off fuel valve. Turn off water supply and drain as much water from pump as possible. Remove water supply hose from inlet.

If you are in a cold climate, see Freeze Protection. **Jetter Hose Reels**

Use the SHR-200 or SHR-300 hose reels when clearing inside drain lines with the gas jet in order to use the high pressure jet without the danger of fumes in the building.

Position the reel at the drain site. Connect the hose from the jet machine to the inlet on the reel. Select end attach a nozzle to the nose on the reel. Put the hose 2 to 3 ft. into the drain line. Open the ball valve on the reel. Follow the start up procedures.

### SFP Foot Pedal (Optional)

The foot pedal is used with any Jetter manufactured by us (see pages 6 or 7). It interrupts the flow of water between the pump and the nozzle while leaving both hands free to guide the hose. The pump will continue to run in by-pass mode. Do not leave pump in by-pass for more than a few minutes or the pump can be damaged.

(See Regulating Pressure Unloader). The foot pedal may be hooked up either at the machine or remotely at the drain site. To use the foot pedal at the machine, remove the hose going to the swivel on the hose reel and attach it to the inlet side

## SAFETY

of the foot pedal. Then connect the accessory hose #8 97-B-190.0 between the outlet of the pedal and the swivel on the hose reel. Some jet models may need the added length of the accessory hose on the inlet side of the pedal.

For remote hookup, pull the hose from the hose reel to the drain site. Attach the hose to the inlet of the pedal.

The pedal is designed for 3/8" hose fittings. If using a 1/4" hose, use adapter #8.705-129.0 as well. Then attach the smaller nose (1/8" or 1/4") to the outlet side of the pedal. Use the smaller hose to clear the drain line.

### Ice Blockages

High pressure water can be used to clear an ice blockage.

A 3000 psi (207 bar) gas jet can clear a 4" (102mm) line at an approximate rate of one foot per minute. The smaller electric jet will take twice as long. Ambient air temperature will effect these times. Use a nozzle with a forward jet. DO NOT allow the incoming water supply to exceed 140°F (60°C) or it could cause damage to the pump. Remember to follow the cold weather precautions found in the freeze protection section.

### Spray Wand (Optional)

Follow the same procedures listed previously for safety, set-up, operation and maintenance. To operate the spray wand, connect the high pressure hose and trigger to the machine. Turn on the water supply, then squeeze the trigger to purge air from the system. Continue to squeeze trigger as you start the machine.

Use caution when pressure washing. Wear goggles and rubber gloves and boots. Analyze angle of spray and anticipate angle of back splash. Do not point spray at anyone including yourself. Do not put your hand in front of water spray. It can penetrate the skin and cause a need for amputation. It is best to start at a 45° angle at a 7 to 10 ft. (2 to 3m) distance from object to be cleaned. Direct spray at close range can be powerful enough to cause damage.

**NOTE: Typical industry standard stipulates you hold the high pressure spray nozzle approximately 6-8" from the surface to be cleaned.**

When cleaning with a detergent, apply from bottom up with an even left to right movement. Rinse from top down with a similar motion. This will help reduce potential streaking. Always apply soap to a dry surface. This will enhance penetration and detergent cling and reduce dilution of detergent with an already wet surface.

If you have the dual lance wand (optional) you may draw detergents through the spray wand in conjunction with the detergent injector mounted on the machine. First set up the detergent injector system (see Detergent Injector).

Then simply turn the knob on the wand counterclockwise so that water is flowing through the wide spray nozzle. To spray water only, turn the knob to the clockwise position so that the water flows through the narrow spray nozzle.

The spray wand option with the other jets may also be used to spray detergent. To do so, simply turn the nozzle on the end of the wand counterclockwise. As the spray widens, more of the detergent will be drawn through the wand. Turn the nozzle clockwise to reduce the detergent flow and narrow the water spray pattern and return to high pressure.

### Detergent Injector (Optional)

The detergent injector is an option with the SDDG-3011 and can be attached to the free end of the ball valve.

Do not attach detergent injector to the inlet side of the pump. Detergents can damage pump. To use the detergent injector, attach one end of siphon hose to the injector and put the filler end in the detergent solution. Be sure the end of the hose is at the bottom of the container or bucket. Some models have adjustable valves to control the amount of detergent drawn through the hose.

**REMEMBER: Do not use corrosive material. See warning previously listed.**

### Regulating Pressure Unloader

The machine is equipped with a regulating pressure unloader to prevent pressure overload in the event that the nozzle is plugged or the ball valve or trigger is shut off. When the machine is in the by-pass mode, the pump will continue to run. However, running in by-pass mode for extended periods will cause damage to the pump, no more than 5 minutes with the SDDG-3011 pump.

Excessive temperatures will damage the pump and void the warranty. The machine also comes with thermal overload protection.

When water temperature in pump increases to 140°F (60°C), the thermal relief valve will release hot water and allow cool water to enter pump from fresh water supply.

To adjust unloader, loosen lock nut and turn the knob clockwise to increase pressure and counterclockwise to decrease pressure.

**Caution: Do not overtighten unloader. Tighten lock nut after adjustments are made.**